

VIKING AGE COSTUMES

By: Keith Nelson

Kirtle :

← SEW CONTRAST FACING INSIDE, THEN TURN OUT.

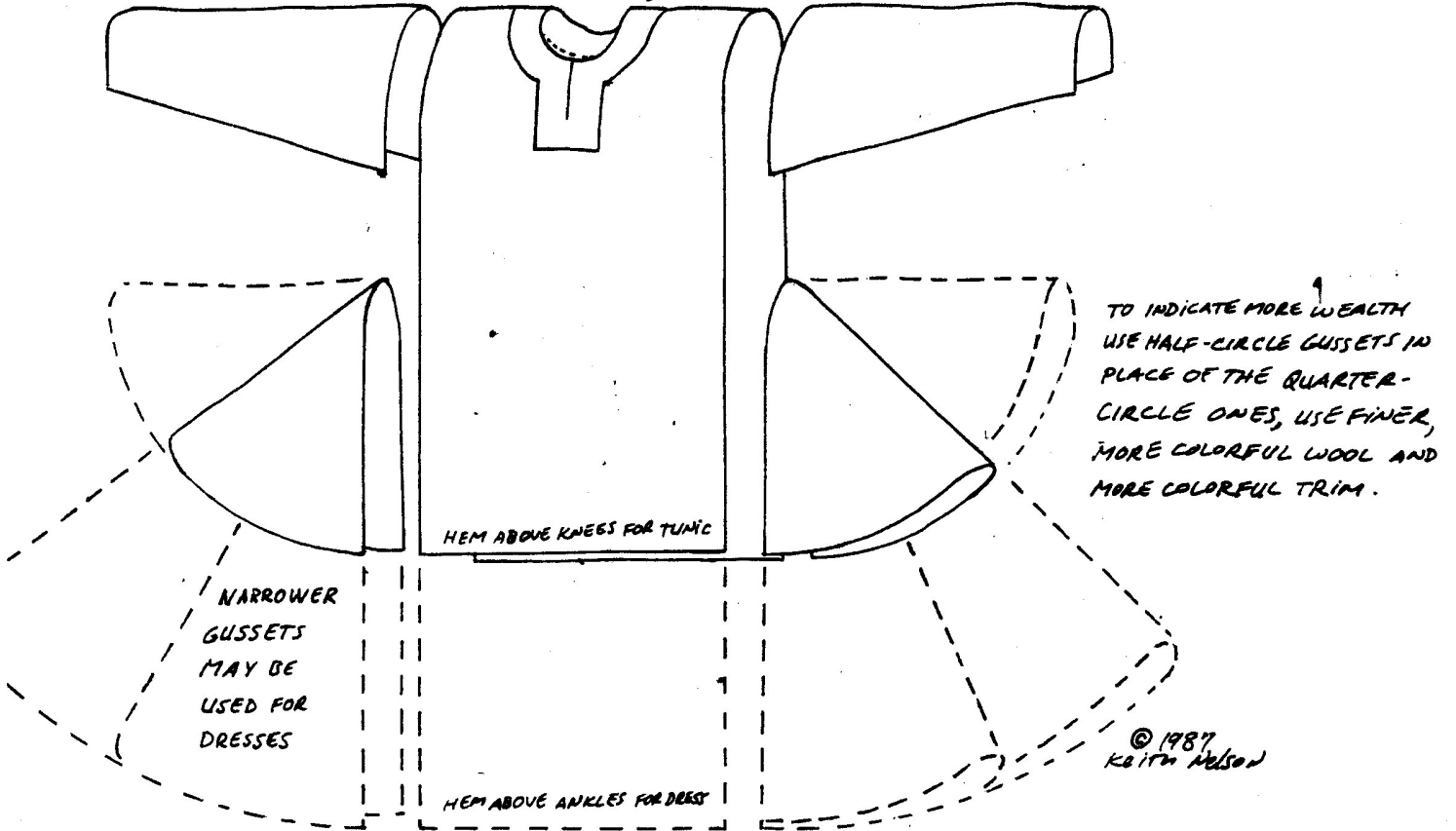

MEASUREMENTS:*

- Ⓐ SHOULDER TO WHEREVER YOU WANT YOUR HEM
 - Ⓑ 1/2 DISTANCE AROUND CHEST, PLUS 5"
 - Ⓒ WAIST TO HEM
 - Ⓓ WRIST TO WRIST OVER SHOULDERS, MINUS Ⓑ, AND DIVIDED IN HALF.
- * LAY OUT PATTERN ON CLOTH, THEN ADD 1/2" SEAM ALLOWANCE TO ALL EDGES THAT WILL BE SEWN
LAYOUT FOR TUNIC FROM 2 1/2 YARDS OF 48" WIDE FABRIC

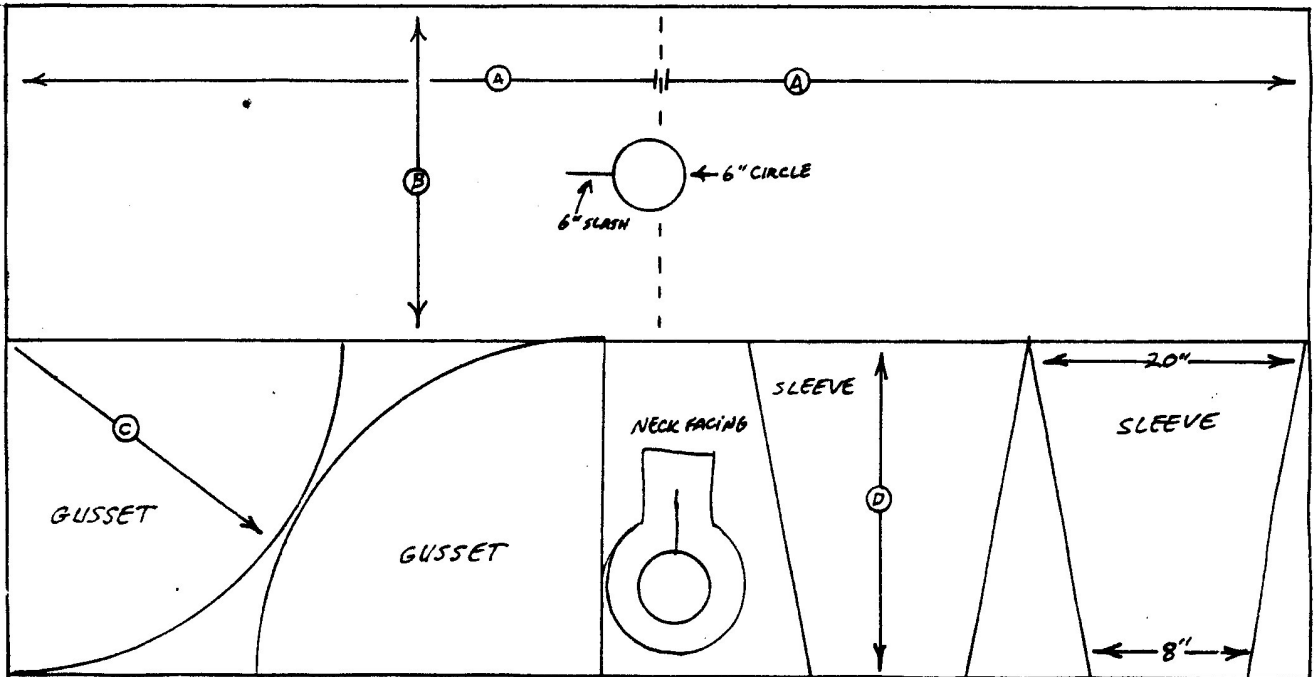

← PUTTING END OF SLEEVES AT EDGE MEANS NO HEMMING AT WRIST

Short Breeks

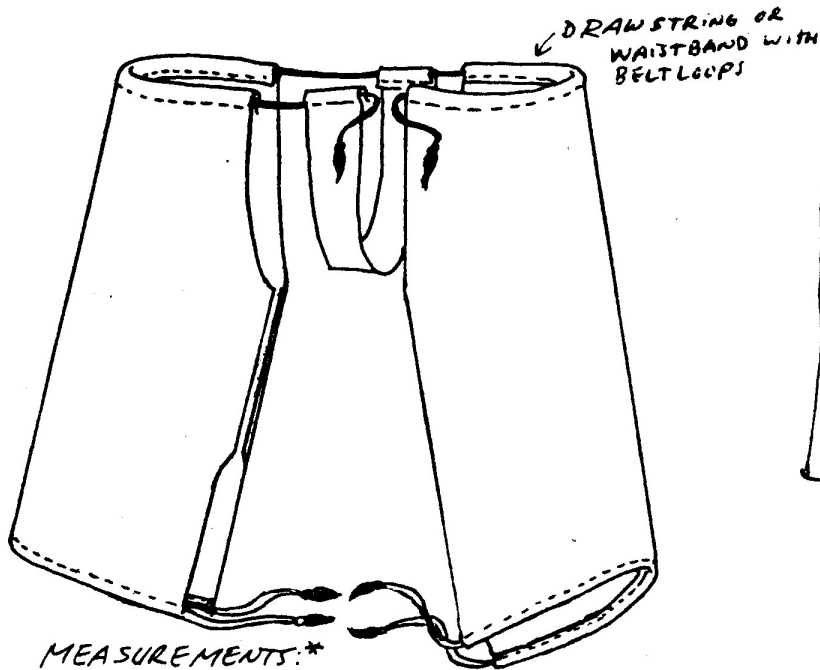

DRAWSTRING OR WAISTBAND WITH BELTLOOPS



© KEITH NELSON 1987

MEASUREMENTS:*

- Ⓐ INSEAM TO MID-CALF.
- Ⓑ CIRCUMFERENCE OF THIGH AT CROTCH
- Ⓒ WAIST TO CROTCH, + 4 INCHES
- Ⓓ 1/2 OF WIDEST PART OF HIPS

Ⓔ 2X LENGTH FROM WAIST CORNER TO CROTCH CORNER

* LAY OUT PATTERN WITH CHALK OR A PIECE OF BAR SOAP, THEN ADD 1/2" TO ALL EDGES THAT ARE TO BE SEWN, AND 1" TO ANY EDGE WHERE YOU WANT A DRAWSTRING.

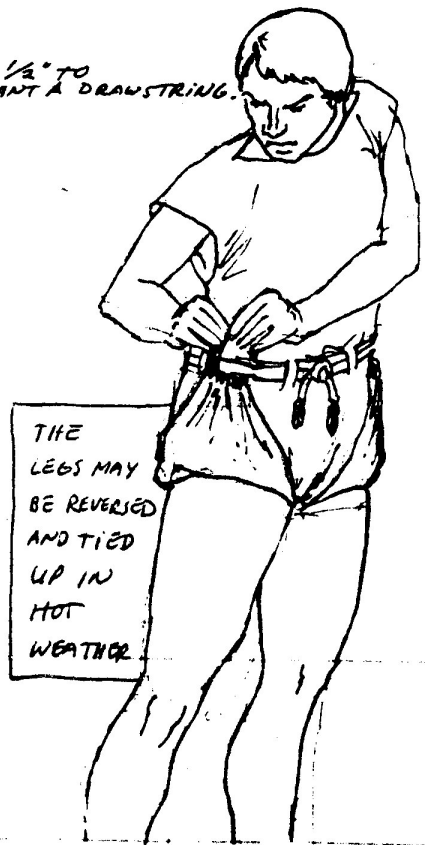
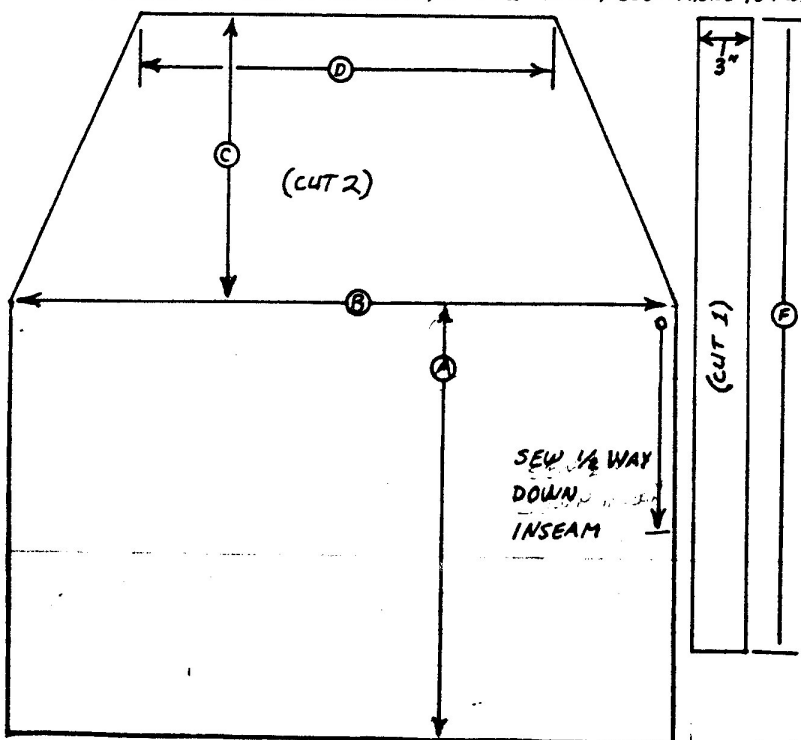

THE LEGS MAY BE REVERSED AND TIED UP IN HOT WEATHER

Breeks-Hose

← WAIST BAND WITH BELT LOOPS IS OPTIONAL

AS THE FEET POINT OUT, THERE IS NO FRONT OR BACK. WHEN THE KNEES WEAR THROUGH, TURN THEM AROUND.

FOR SHORT HOSE, CUT LEGS TO REACH TO KNEES AND GARTER THEM.

FOR LONG PANTS; OMIT FEET

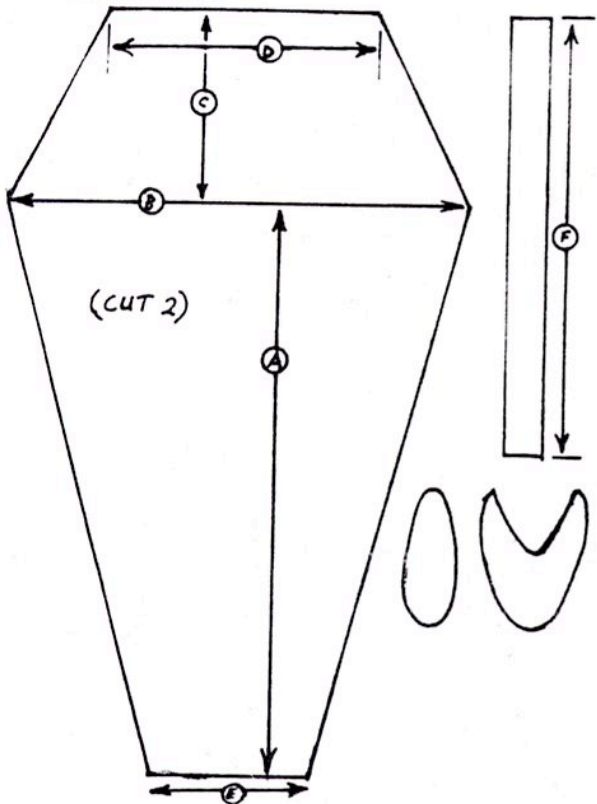
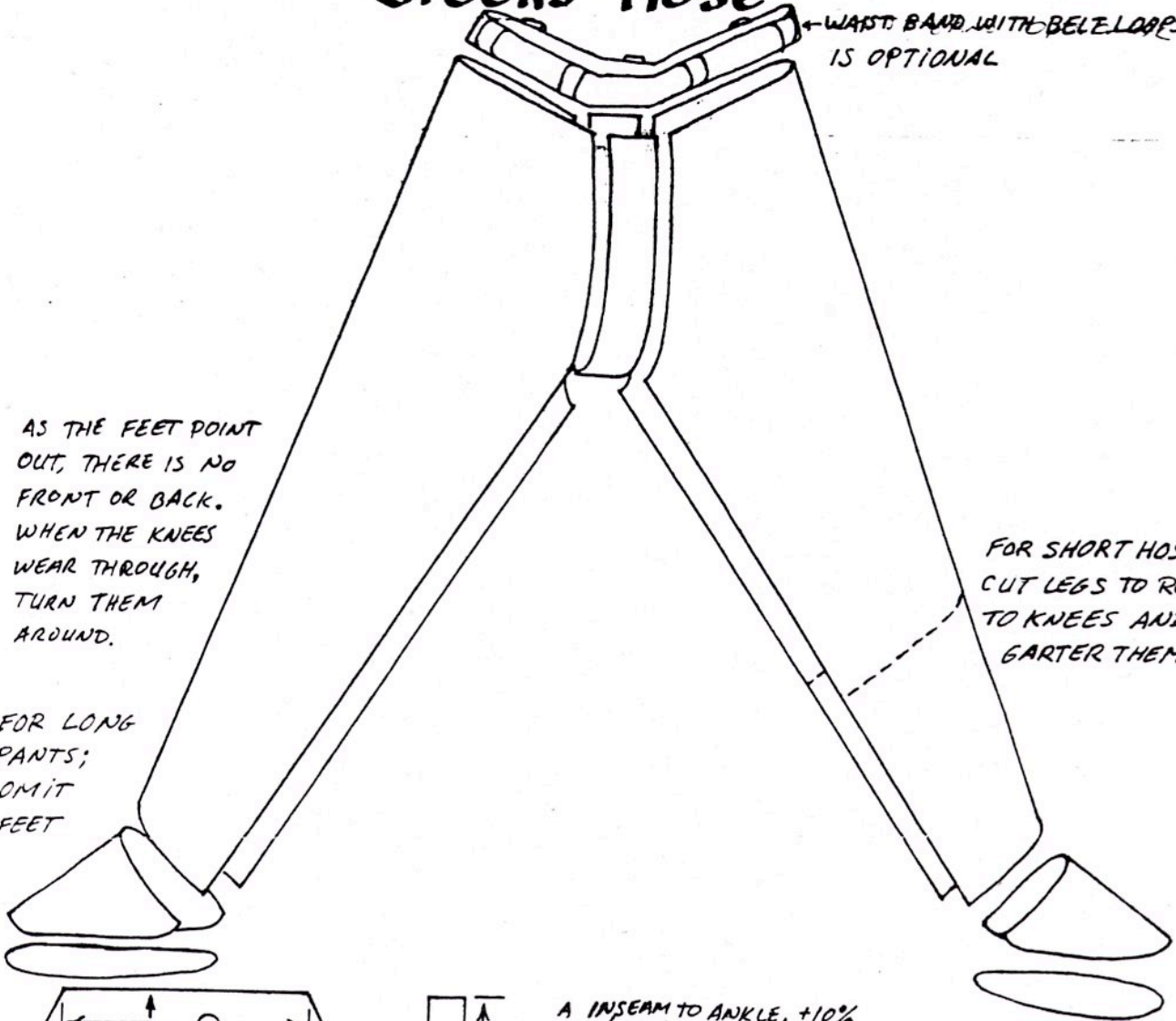

- A INSEAM TO ANKLE, +10% (MULTIPLY BY 1.10)
- B CIRCUMFERENCE OF LEG AT CROTCH
- C 1/2 THE DISTANCE FROM FRONT WAIST TO BACK WAIST UNDER CROTCH.
- D 1/2 WAIST MEASUREMENT
- E AROUND ANKLE FROM HEEL OVER INSTER
- F 2 TIMES DISTANCE FROM WAIST CORNER TO CROTCH CORNER

FOR LONG BREEKS:
 OMIT FOOT
 DO NOT LENGTHEN INSEAM
 INCREASE ANKLE WIDTH BY 1/2

Hooded Cloaks

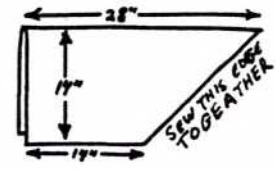
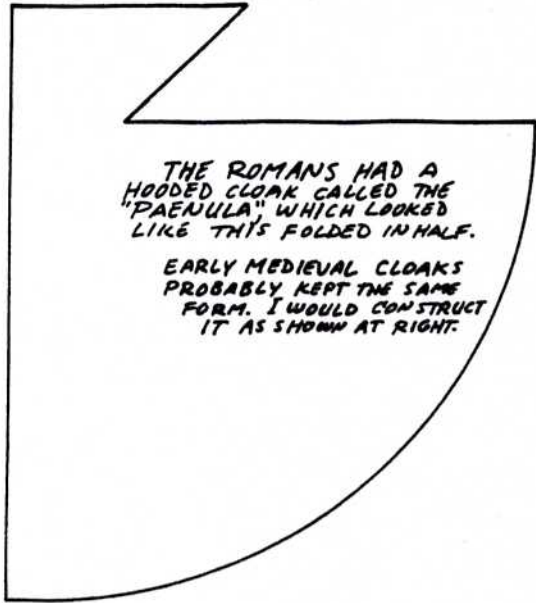

FOR A POINTED HOOD, TRY THIS PATTERN

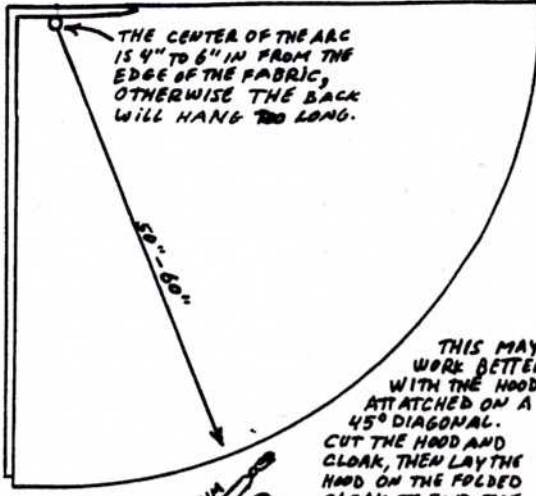

THIS MAY WORK BETTER WITH THE HOOD ATTACHED ON A 45° DIAGONAL. CUT THE HOOD AND CLOAK, THEN LAY THE HOOD ON THE FOLDED CLOAK TO FIND THE PROPER LINE TO CUT.



Hood

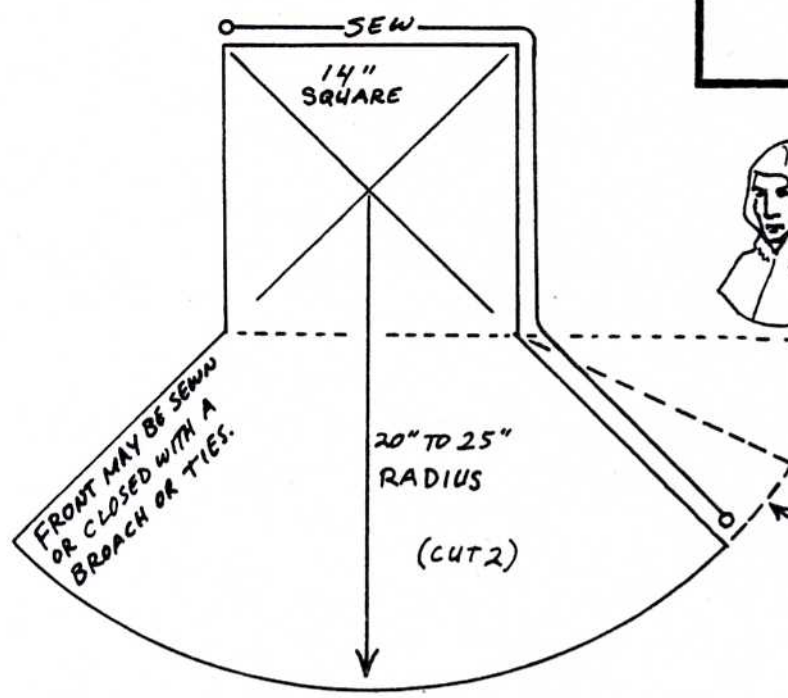

IF YOU FIND YOU NEED MORE ARM MOVEMENT, LEAVE THE FRONT OPEN OR EXTEND THE SHOULDER

← CAPE HALF WAY TO THE BASE LINE OF THE HOOD

©1989 KEITH NELSON

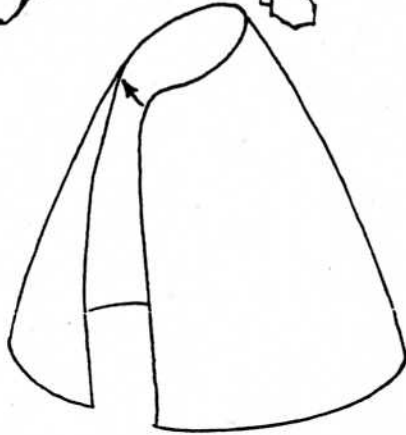
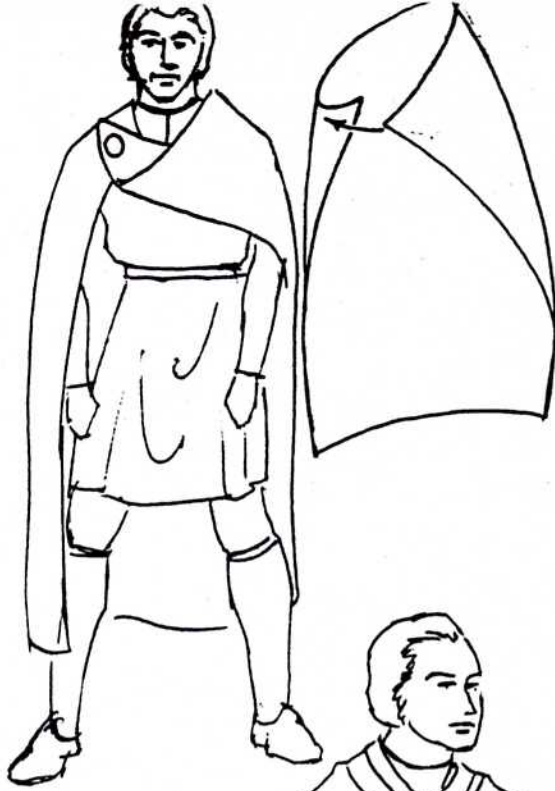

©1994 KEITH NELSON

- Ⓐ LENGTH FROM SHOULDER TO MID-CALF
- Ⓑ LENGTH AROUND SHOULDERS

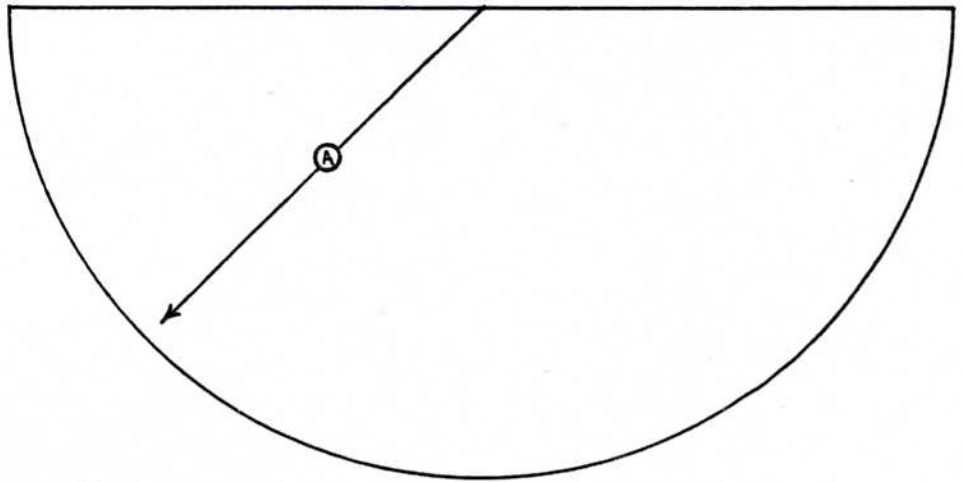
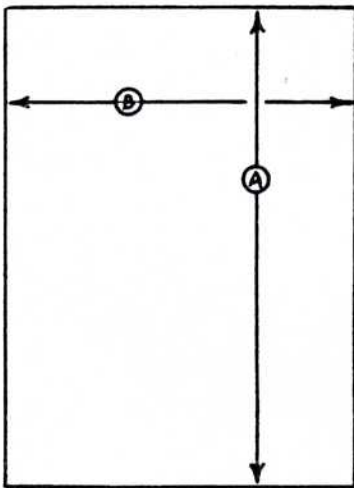

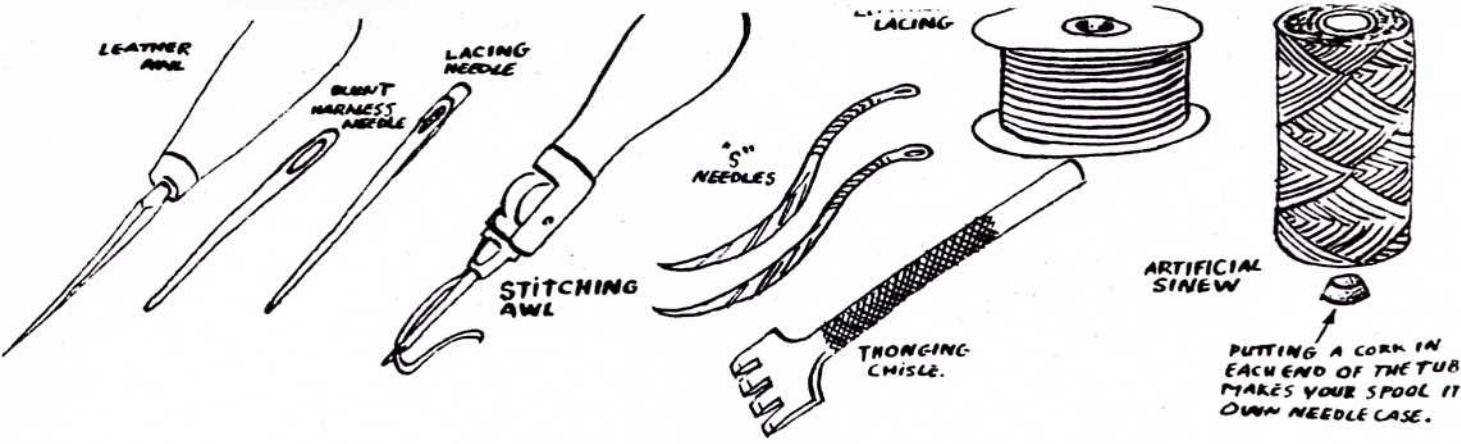

WHEN ONE THREAD BREAKS...

STITCHING AWL
LOCK STITCH



BOTH THREADS LOOSEN

TWO-NEEDLE
SADDLE-STITCHING



WHEN ONE THREAD BREAKS
THE OTHER STAYS TIGHT.

FALSE SEAMS WERE
POPULAR FROM THE VIKING
AGE THROUGH THE
CRUSADES. THEY WERE
USUALLY ON THE VAMP
(UPPER OVER FRONT OF
FOOT) OR RADIATING
FROM THE IN STEP

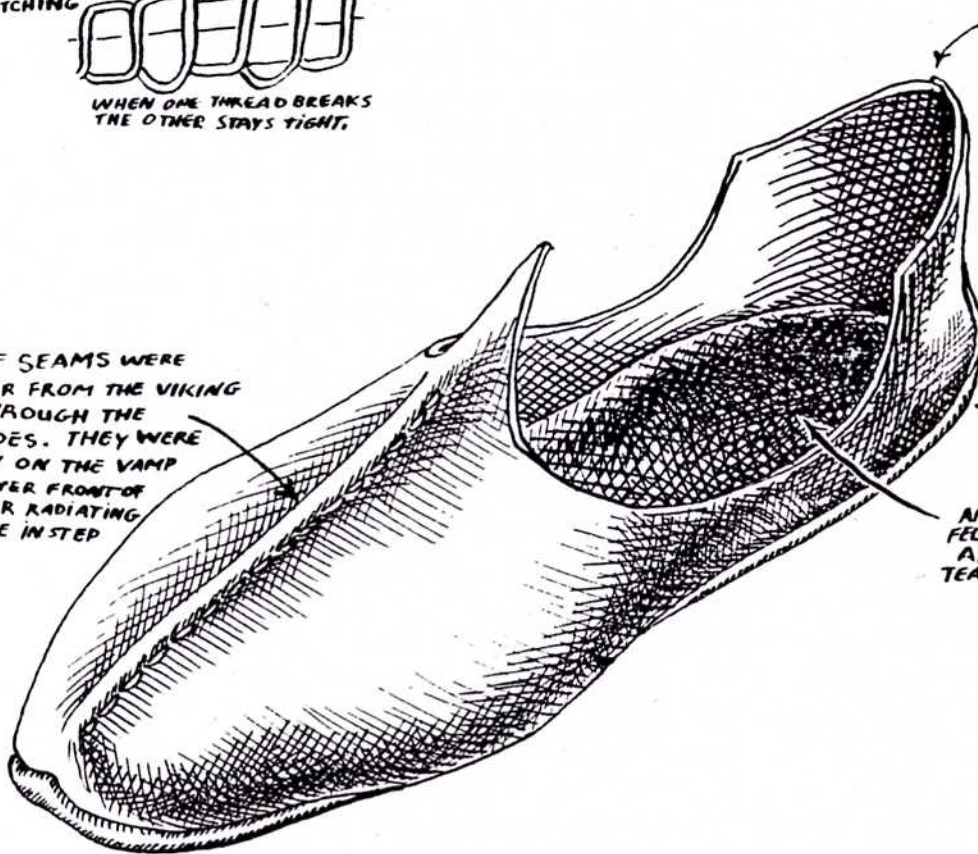

AN INSOLE OF 1/4" THICK
FELT SAVES AN IMMENSE
AMOUNT OF WEAR AND
TEAR ON THE FEET.

SOLE SEAM
(TURNED IN)

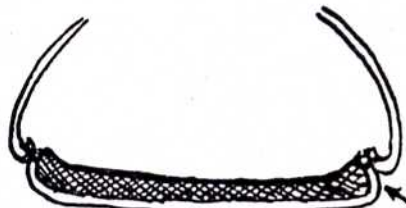

FELT INSOLE SHOULD PRESS
AGAINST INSIDE OF SOLE SEAM

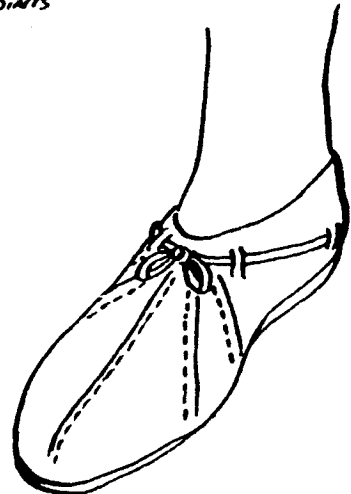
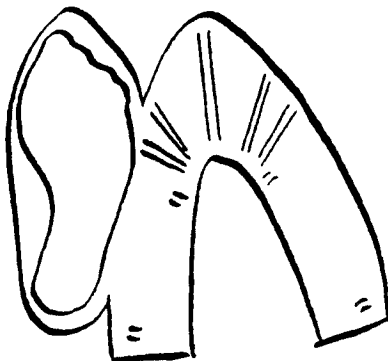
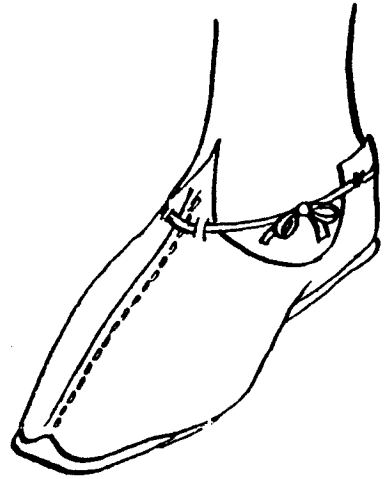
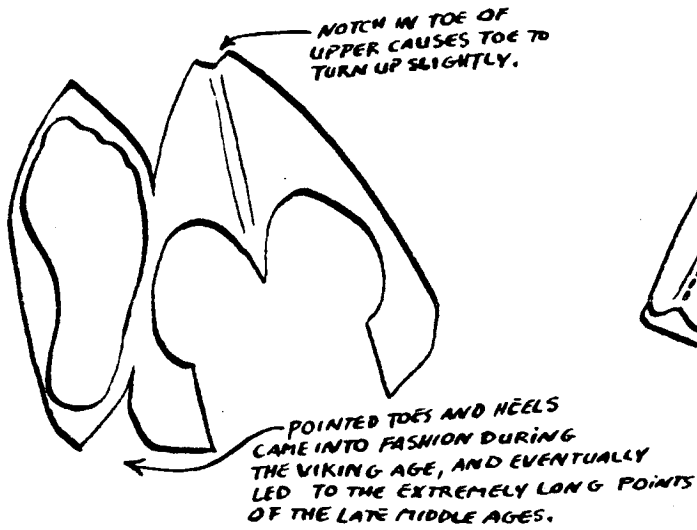
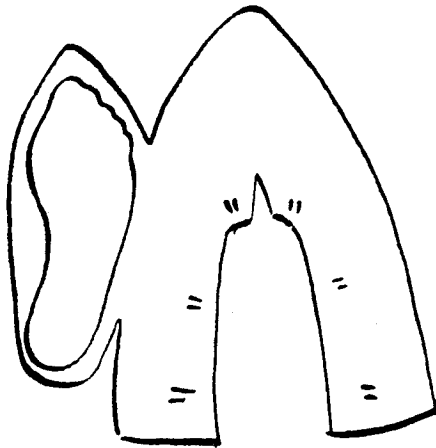

LACES OFTEN DROPPED LOW AT THE BACK OF THE FOOT

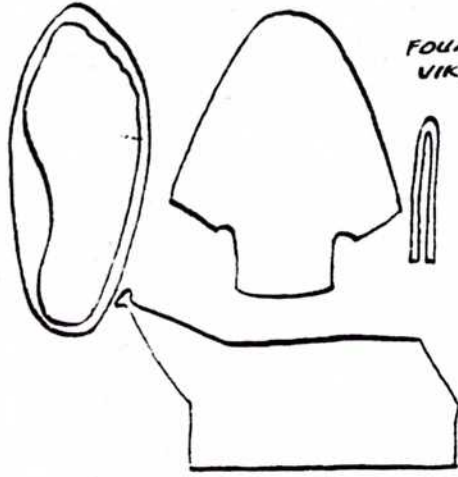

FOUND AT YORK, IN THE VIKING AGE LEVELS



^ ^

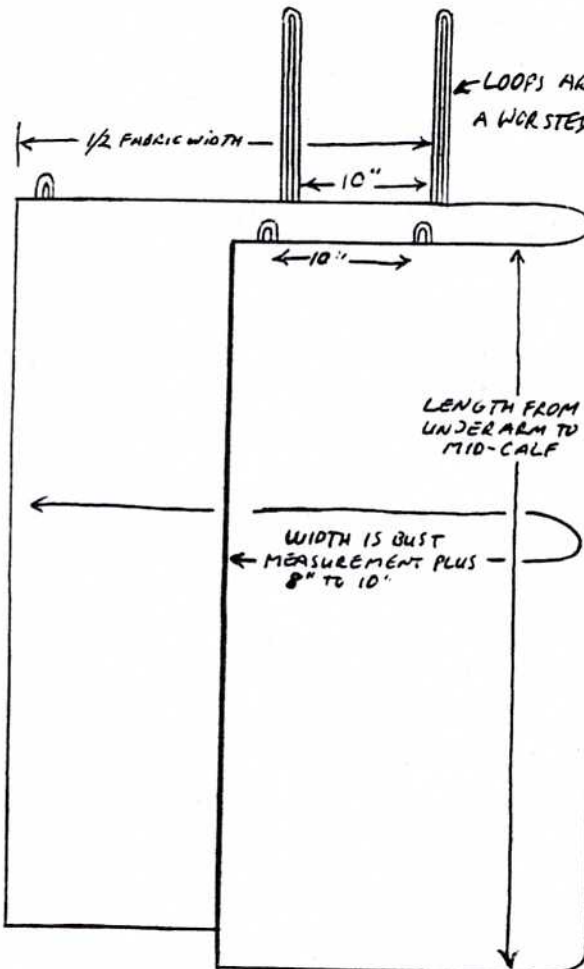

← LOOPS ARE LINEN ATTACHED TO A WORSTED WOOL BODY



WEAR OVER A CHEMISE AND DRESS CUT FROM THE KIRTLE PATTERN SHEET.

ONE BRACH SECURES BOTH END LOOPS AT RIGHT FRONT



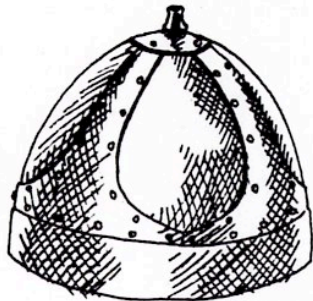

ORIGINAL HAS HOLES ALONG
BOTTOM EDGE, INDICATING A
MAIL NECK PROTECTION

MORAVIA
DATED 600'S

MORAVIAN PRE-975
ORIGINAL STAMPED, SILVERED
AND GILDED
AN ALMOST IDENTICAL HELM WAS
FOUND IN 1957 AT MORAVEN NEAR
COLOGNE. ANOTHER AT THE MET
HAS ORANGE RIBS & IRONPLATES.

MORAVIAN- PRE 975

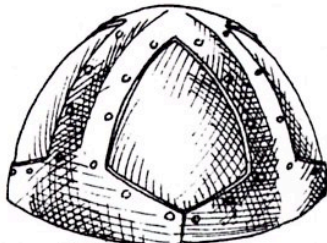

ORIGINAL GILDED

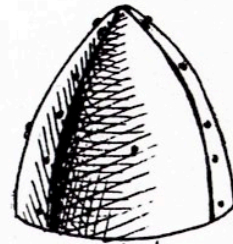

POLISH
TOWER OF LONDON
IRON

ASSUMED POSITION OF
NASSEL, SINCE BARRON OFF

A SIMILAR HELM, THOUGH LESS POINTED,
HAS A NASSEL CUT IN ONE PEICE WITH THE
FRONT PANEL, CENTERED ON PANEL.

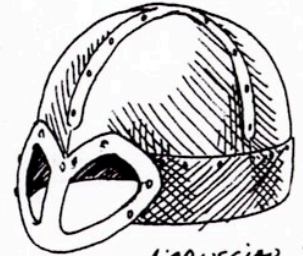

NORWEGIAN 900'S:
FOR DETAILS SEE
DEANIS' HELM.

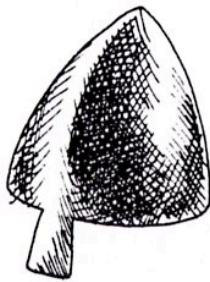

MORAVIAN
1000'S
KUNSTHISTORISCHES
MUSEUM, VIENNA
WSA 41
THIS HELM HAS NO
OBVIOUS SEAMS

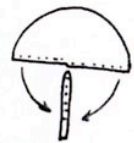

ENTIRELY CONJECTURAL
HELM IS BARRON AS IT IS ROLLED INTO CONE